

High-Current Low-Inductance DC Capacitors

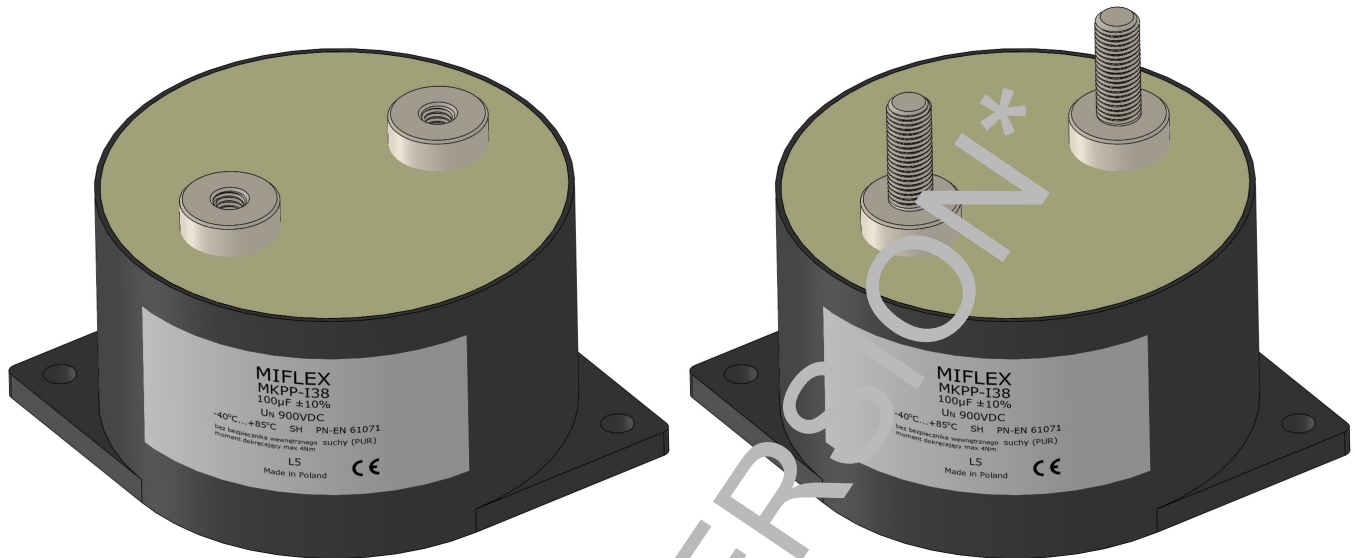

General characteristics

MKPP-I38 capacitors are power electronics capacitors for use in DC and DC circuits variable with values in accordance with technical data. They meet the requirements of the EN 61071 standard regarding capacitors for power electronics devices. The construction of the capacitors minimizes the parasitic inductance, and the self-healing film system metallized improves their safety.

The low inductance and series resistance of the capacitors allows their use in applications in which high current pulses will flow through the capacitors. Capacitors are made in a cylindrical plastic housing, capacitor winding element is hermetically sealed with an insulating resin.

Capacitors can be used in AC and DC power converters as DC Link capacitors connected to DC busbars. They are characterized by considerable resistance to pulsed currents, high energy density, wide range of rated voltages, long life, ease of connection and lack of polarity. They do not contain harmful, liquid electrolytes and other hazardous substances.

ATTENTION:

The capacitors are not equipped with a discharging device, voltage and energy level stored in capacitors is dangerous for human health and life. Be especially careful during assembly, service and maintenance of devices containing these capacitors.

*) - the dimensions and parameters of the capacitors may change

MIFLEX S.A.

ZAKŁADY PODZESPOŁÓW RADIOWYCH
99-300 KUTNO, ul. GRUNWALDZKA 3

Telephone: +48 24 355 11 00

Fax: +48 24 355 11 88

e-mail: miflexsa@miflex.com.pl



Fundusze Europejskie
Program Regionalny



Unia Europejska
Europejskie Fundusze
Strukturalne i Inwestycyjne



Revision date

21.10.2021

Edition 2

Page

1/5

High-Current Low-Inductance DC Capacitors

Basic technical data

Capacitance range	see tab. 1
Capacitance tolerance	K: $\pm 10\%$
Dielectric dissipation factor ($\text{tg}\delta_0$)	0,0002
Expected lifetime	100 000h @ θ_{hs} to U_{NDC}
Minimum operating temperature θ_{min}	-40°C
Maximum operating temperature θ_{max}	+70°C
Hottest ambient point θ_{hs}	+85°C (+70°C for 450V and 600V)
Insulation resistance	$C \times R_{is} \geq 5000s$
IEC climatic category	40/070/56
Humidity class	maximum relative humidity: 65% on average per year, occasionally 75%, 85% 60 days a year, condensation is not allowed
Maximum operating altitude	2000m above sea level

Type and parameters of tests

Electrical strength between terminals U_{TT}	1,5 U_{NDC} , 10s
Endurance testing	according to EN 61071

Design data

Dielectric type	metallized polypropylene with self-healing properties
Filling	without PCB, solid insulation resin
Working position	any
Type of work	continuous
Cooling	natural or forced
Housing	V0 plastic
Level of protection	IP00
Protection	no internal protection
Discharging device	none
Terminals type	radial with internal or external thread M8
Insulation spacing - on the surface of L_u	25mm
Insulation spacing - in the air of L_p	25mm
Tightening torque at terminals M_v	10Nm
Tightening torque at housing base M_p	2Nm
Overload, maximum allowable voltage	1,10 U_{NDC} 30% of working time in one day 1,15 U_{NDC} 30 min /d 1,20 U_{NDC} 5 min /d 1,30 U_{NDC} 1 min /d 1,50 U_{NDC} 30ms not more than 1000 times during the life time

Standards, directives, certificates

EN 61071 - Capacitors for power electronics
RoHS
REACH
UL 94



ZAKŁADY PODZESPOŁÓW RADIOWYCH
99-300 KUTNO, ul. GRUNWALDZKA 3

Telephone: +48 24 355 11 00

Fax: +48 24 355 11 88

e-mail: miflexsa@miflex.com.pl



Fundusze Europejskie
Program Regionalny



Unia Europejska
Europejskie Fundusze
Strukturalne i Inwestycyjne



Revision date

21.10.2021

Edition 2

Page

2/5

High-Current Low-Inductance DC Capacitors

Storage and use

It is suggested not to store capacitors for more than 5 years. After 1 year of storage, it is recommended to perform initial measurement of capacitance and $\tan\delta$ factor before switching on the power supply.

The polypropylene film capacitors do not require electric formatting before use (as in the case of electrolytic capacitors).

Storage conditions to be met:

- relative humidity: 75% on average per year
- maximum relative humidity: 95%, 30 days a year
- condensation: not allowed
- minimum storage temperature: -40 °C
- maximum storage temperature: + 70 °C

Capacitors should be stored in closed rooms with no corrosive atmosphere (for example the presence of chlorides and gaseous sulphides, acids, alkaline substances, salts or equivalents are not permitted substances). Packed capacitors should be transported carefully, especially while using a forklift.

Terms and definitions

- U_{NDC} - Rated DC voltage for which the capacitor has been designed for continuous operation.
- U_s - Unique impact voltage. Peak value of voltage caused by switching operations or other disturbances in the system operation, with a duration shorter than the period of the basic course, the occurrence of which is allowed a limited number of times.
- f_{max} - Maximum working frequency.
- C_N - Rated capacity measured at 20°C ± 5°C at 1kHz frequency and 1V voltage.
- I_{max} - Maximum effective value of the current during continuous operation.
- \hat{i} - Maximum peak current. Maximum, repeatable peak current value that can occur during continuous operation.
- \hat{i}_s - Maximum impact current. Peak value of current caused by switching operations or other disturbances in the work of the system, with a duration shorter than the period of the basic course, the occurrence of which is acceptable in a limited number of times.
- L_s - Self-inductance. Sum of inductances of all internal capacitor elements.
- R_s - Series resistance. Resistance of capacitor current paths under specific operating conditions.
- R_{th} - Thermal resistance. Indicates how many degrees the temperature of the capacitor rises in the hottest point due to power losses.
- θ_{amb} - The temperature of the cooling air. The temperature of the cooling air measured in the hottest spot of a capacitor bank, in conditions set at half the distance between two capacitors, in the case of a single capacitor, this is the temperature measured at a point about 0.1 m away from the housing in 2/3 of the height of the capacitor, measured from the base.
- θ_{min} - The lowest operating temperature. The lowest temperature of the dielectric, at which voltage applied can be connected to the capacitor terminals.
- θ_{max} - Maximum working temperature. The highest temperature of housing at which the capacitor can work.
- θ_{hs} - The temperature of the hottest point of the capacitor. The temperature θ_{hs} can be estimated in accordance with the given formula. During operation, the temperature θ_{hs} cannot be exceeded. At rated load and not exceeding this temperature, the expected lifetime will be consistent with the given value with the statistical failure rate of 300FIT.
- R_{esr} - The equivalent series resistance of the capacitor, which in series with the capacitor of the capacity equivalent to capacitance of the considered capacitor, will cause in it a loss of power equal to the active power released in the capacitor under specific operating conditions.
- P_{max} - Maximum power loss. Maximum power loss allowed at maximum temperature of the capacitor housing.

$$P_{max} = \frac{\theta_{hs} - \theta_{amb}}{R_{th}}$$



ZAKŁADY PODZESPOŁÓW RADIOWYCH
99-300 KUTNO, ul. GRUNWALDZKA 3

Telephone: +48 24 355 11 00

Fax: +48 24 355 11 88

e-mail: miflexsa@miflex.com.pl



Fundusze Europejskie
Program Regionalny



Unia Europejska
Europejskie Fundusze
Strukturalne i Inwestycyjne



Revision date

21.10.2021

Edition 2

Page

3/5

High-Current Low-Inductance DC Capacitors

Capacitance	Height / Diameter	Effective current maximum value	Maximum peak current	Maximum impact current	Self-inductance	Serial resistance	Thermal resistance	Weight	Index (*)
CN(μF)	H / D [mm]	I _{max} (A)	I _∧ (kA)	I _s (kA)	L _s (nH)	R _s (mΩ)	R _{th} (°C/W)	m (kg)	
U _{NDC} =450V U _S =900V ¹⁾ f _{max} =10kHz									
250	54 / 88	80	6,9	10,3	30	0,39	10	0,45	I38CF725K-...
350	68 / 88	67	6,1	9,2	40	0,63	8,8	0,55	I38CF735K-...
610	97 / 85	64	6,4	9,7	57	0,95	6,4	0,75	I38CF761K-...
U _{NDC} =600V U _S =1200V ¹⁾ f _{max} =10kHz									
180	54 / 88	73	5,8	8,7	30	0,47	10	0,45	I38DA718K-...
280	68 / 88	65	5,7	8,6	40	0,68	8,8	0,55	I38DA728K-...
440	97 / 85	59	5,4	8,1	57	1,13	6,4	0,75	I38DA744K-...
U _{NDC} =700V U _S =1400V ¹⁾ f _{max} =10kHz									
140	54 / 88	76	5,1	7,7	30	0,52	10	0,45	I38DK714K-...
220	68 / 88	67	5,1	7,7	40	0,76	8,8	0,55	I38DK722K-...
340	97 / 85	60	4,8	7,2	57	1,28	6,4	0,75	I38DK734K-...
U _{NDC} =900V U _S =1800V ¹⁾ f _{max} =10kHz									
100	54 / 88	70	4,4	6,6	30	0,61	10	0,45	I38EK710K-...
150	68 / 88	61	4,2	6,3	40	0,92	8,8	0,55	I38EK715K-...
230	97 / 85	54	3,9	5,8	57	1,58	6,4	0,75	I38EK723K-...
U _{NDC} =1000V U _S =2000V ¹⁾ f _{max} =10kHz									
75	54 / 88	65	3,8	5,7	30	0,71	10	0,45	I38FA675K-...
120	68 / 88	58	3,9	5,8	40	1,01	8,8	0,55	I38FA712K-...
180	97 / 85	52	3,5	5,2	57	1,76	6,4	0,75	I38FA618K-...
U _{NDC} =1100V U _S =2200V ¹⁾ f _{max} =10kHz									
65	54 / 88	63	3,5	5,3	30	0,76	10	0,45	I38FK665K-...
100	68 / 88	55	3,4	5,2	40	1,13	8,8	0,55	I38FK710K-...
160	97 / 85	50	3,3	5,0	57	1,85	6,4	0,75	I38FK716K-...
U _{NDC} =1250V U _S =2500V ¹⁾ f _{max} =10kHz									
50	54 / 88	59	3,1	4,7	30	0,86	10	0,45	I38GF650K-...
75	68 / 88	51	3,0	4,5	40	1,31	8,8	0,55	I38GF675K-...
120	97 / 85	47	2,9	4,3	57	2,14	6,4	0,75	I38GF712K-...
U _{NDC} =1450V U _S =2900V ¹⁾ f _{max} =10kHz									
40	54 / 88	56	2,8	4,2	30	0,96	10	0,45	I38HF640K-...
50	68 / 88	44	2,2	3,3	40	1,75	8,8	0,55	I38HF650K-...
95	97 / 85	44	2,5	3,8	57	2,42	6,4	0,75	I38HF695K-...
U _{NDC} =1800V U _S =3600V ¹⁾ f _{max} =10kHz									
25	54 / 88	50	2,3	3,4	30	1,18	10	0,45	I38JA625K-...
35	68 / 88	42	2,0	3,0	40	1,94	8,8	0,55	I38JA635K-...
60	97 / 85	40	2,1	3,1	57	2,99	6,4	0,75	I38JA660K-...
U _{NDC} =2000V U _S =4000V ¹⁾ f _{max} =10kHz									
20	54 / 88	48	2,0	3,1	30	1,32	10	0,45	I38KA620K-...
30	68 / 88	41	1,9	2,9	40	2,03	8,8	0,55	I38KA630K-...
47	97 / 85	37	1,8	2,7	57	3,42	6,4	0,75	I38KA647K-...
U _{NDC} =2200V U _S =4400V ¹⁾ f _{max} =10kHz									
16	54 / 88	45	1,8	2,7	30	1,51	10	0,45	I38LA616K-...
25	68 / 88	39	1,7	2,6	40	2,22	8,8	0,55	I38LA625K-...
39	97 / 85	35	1,6	2,4	57	3,77	6,4	0,75	I38LA639K-...

1) - no more than 1000 times during the life time

2) - mass of the capacitor with internal thread, for the version with external thread, add 22g

3) - end of the index, respectively: ...- W ... for a connector with an internal thread, ...- Z ... for a connector with an internal thread
...-... 6 for a connector with an M6 thread, ...-... 8 for a connector with an M8 thread

Other capacitances and voltages are possible - according to individual arrangements

High-Current Low-Inductance DC Capacitors

Drawing 1

Version with internal thread
Index ...- W ...

Version with external thread
Index ...- Z ...

